

A Wide-Dynamic-Range (2 μ A–12.6 mA) Closed-Loop BCI Chip With Fast Recovery and Precision Current Stimulation

Yishan Wang, Qi An and Ye Li

Shenzhen Institute of Advanced Technology, Chinese Academy of Sciences

This paper presents a high-performance closed-loop brain–computer interface (BCI) chip that integrates multi-channel neural signal acquisition and high-voltage programmable stimulation with enhanced safety and precision. The proposed chip addresses key limitations in existing BCI systems, including insufficient stimulation range, limited current accuracy, and inadequate protection under high-voltage stimulation conditions.

To ensure reliable neural recording during large-current stimulation, a robust front-end architecture is developed. It incorporates bidirectional stacked electrostatic discharge (ESD) protection capable of tolerating ± 18 V stimulation voltages, input protection networks to prevent amplifier breakdown, and a fast-recovery mechanism that enables signal restoration within 100 μ s after stimulation, significantly reducing artifact-induced saturation.

For stimulation, a wide dynamic range programmable current driver is proposed, supporting three selectable ranges from 2 μ A to 12.6 mA with fine resolution and $<1\%$ current error. Both monopolar (up to 16 channels) and bipolar (8 channels) stimulation modes are supported, providing flexibility for different neural modulation scenarios. A novel high-voltage charge balancing scheme ensures safe operation by eliminating residual charge accumulation, while integrated impedance and fault detection modules enable real-time electrode monitoring and system reliability verification.

Fabricated in a 180 nm BCD process, the chip supports 128-channel neural recording with a bandwidth of up to 7 kHz and an input-referred noise of approximately 4 μ Vrms. Four 12-bit SAR ADCs enable parallel acquisition at up to 20 kS/s, while each channel consumes only ~ 20 μ W. The chip occupies an area of 7×7 mm² and demonstrates robust performance in both simulation and measurement.

Overall, this work provides a highly integrated and safe solution for closed-loop neural interfacing, making it suitable for both implantable and non-invasive neuro-modulation applications.

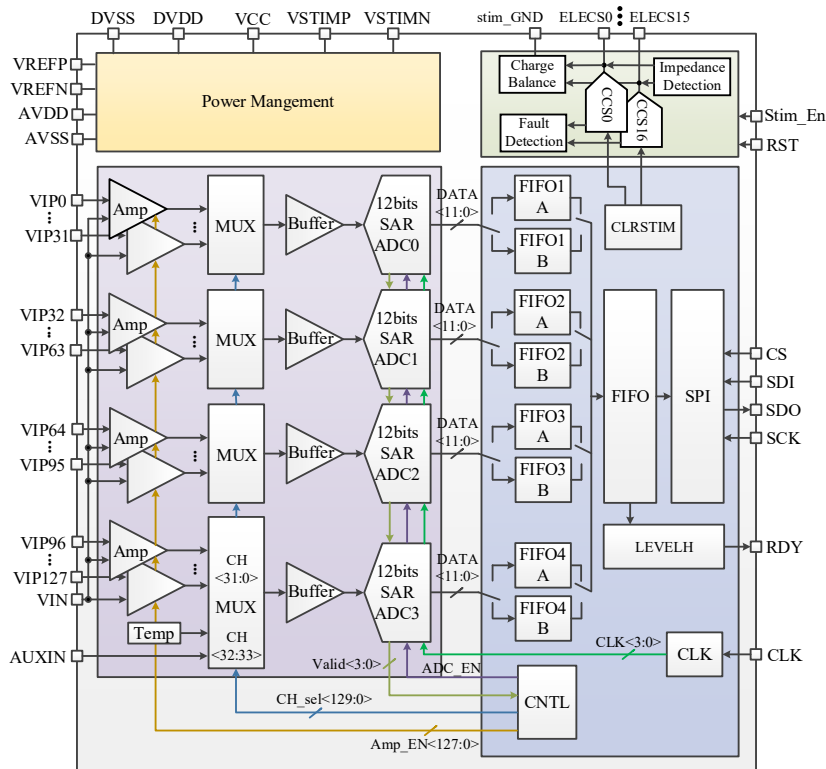

Figure 1: The architecture of the BCI chip